



—

—

ALESSANDRO COMPAGNIN

Tutti gli oggetti sono realizzati artigianalmente direttamente dall'artista tramite le tecniche di lavorazione della vetroresina maturate nel corso degli anni grazie alla lunga esperienza sviluppata nella realizzazione di carrozzerie per auto sportive Lancia Stratos e Osella.

Ulteriore fonte di ispirazione deriva dalla frequentazione costante del mondo Harley Davidson e cultura Hot rod.

Il forte interesse per la personalizzazione degli oggetti di uso quotidiano e la possibilità di dare nuova forma ad essi lo ha portato gradualmente ad approdare nel mondo del design creando questa collezione in itinere, composta da pezzi personalizzabili o realizzati su misura.

All objects are handcrafted directly by the artist using the fiberglass techniques he has developed over the years thanks to his long experience in building bodies for Lancia Stratos and Osella sports cars.

A further source of inspiration comes from constant frequentation of the Harley Davidson world and hot rod culture.

His strong interest in the customization of everyday objects and the possibility of giving them a new shape gradually led him to enter the world of design by creating this ongoing collection of customizable or made-to-measure pieces.



Arte e Tecnica

“L'artista è il creatore di cose belle”. Questo è quanto Oscar Wilde scriveva nella prefazione de “Il ritratto di Dorian Gray”, un vero artista e designer è quindi in grado di creare oggetti belli anche con i materiali più semplici elevandoli al rango di capolavori. Alessandro Compagnin segue questa idea utilizzando la vetroresina, che plasma per dare forma a piccole e grandi meraviglie contemporanee.

Alessandro ha scelto inizialmente di concentrarsi sulla produzione di quadri trasferendogli la volontà di dare corpo alla quotidianità ampliandola poi nella creazione di oggetti quali sedie, tavoli, lampade e molto altro personalizzati in base al cliente, iniziano così a comparire suoi artefatti nelle case e nei locali di amici ed estimatori, accrescendo l'interesse e l'ammirazione nei confronti di questo nuovo designer.

La vetroresina è una sostanza liquida, che l'artista manipola e trasforma nel più resistente dei materiali, per dare forma a idee e personaggi che affollano la sua vita.

Il processo creativo è apparentemente molto semplice: si parte da una fotografia della grafica desiderata, che subisce una rapida elaborazione grafica che ne determina la fattibilità, questa verrà poi riprodotta sulla lastra di vetroresina, appositamente trattata per fungere da supporto all'opera. Per rendere tale sostegno resistente, ed evitare quindi improvvise quanto fastidiose rotture, le viene aggiunto uno strato di fibra, opportunamente amalgamata con l'aggiunta di altra vetroresina liquida.

Un'arte, quella di Alessandro Compagnin, in continua evoluzione, che non ha sicuramente finito di esprimersi in tutte le sue potenzialità. Ma chi conosce questo artista sa che è sempre stato una “pecora nera”.

“The artist is the creator of beautiful things.” This is what Oscar Wilde wrote in the preface to “The Picture of Dorian Gray.” A true artist and designer is therefore able to create beautiful objects even with the simplest materials, elevating them to the rank of masterpieces. Alessandro Compagnin follows this idea using fiberglass, which he molds to give shape to small and large contemporary wonders.

Alessandro initially chose to focus on the production of paintings, transferring to them the desire to give shape to everyday life, then expanding it into the creation of objects such as chairs, tables, lamps and much more, personalized according to the customer. His artifacts began to appear in the homes and businesses of friends and admirers, increasing the interest and admiration for this new designer. Fiberglass is a liquid substance that the artist manipulates and transforms into the strongest of materials to give shape to ideas and characters that crowd his life.

The creative process is apparently very simple: it starts with a photograph of the desired graphics, which undergoes a rapid graphic processing that determines its feasibility. This will then be reproduced on the fiberglass sheet, specially treated to act as a support for the work. To make this support strong, and thus avoid sudden and annoying breakages, a layer of fiber is added, properly blended with the addition of other liquid fiberglass.

The art of Alessandro Compagnin is in constant evolution and has certainly not finished expressing itself in all its potential. But those who know this artist know that he has always been a “black sheep”.

Indice



Sedute
P.2



Pannelli
P.16



Lampade
P.22

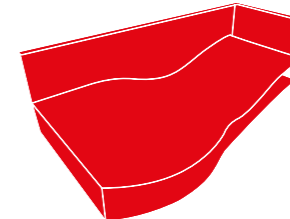

Lavandini
P.26

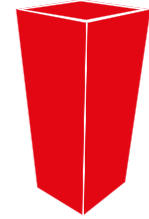

Vasi
P.30



Orologi
P.32



Accessori
P.34



Quadri
P.38



Locali
P.52



Tavoli
P.74



Bus
P.78

about

P.82





SEDUTE

Collezione di sedie e poltrone realizzate con struttura portante completamente in fiberglass e finiture in gelcoat in vari colori ed effetti

SEATS

Collection of chairs and armchairs made with a supporting structure entirely in fiberglass and gelcoat finishes in various colors and effects

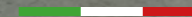





8



9



**RIBBON**

Sedia leggera e resistente, ideale per un uso quotidiano. Bicromatica, il supporto è personalizzabile in base alle proprie preferenze

Lightweight and resistant chair, ideal for daily use. Two-tone, the support can be customized according to your preferences

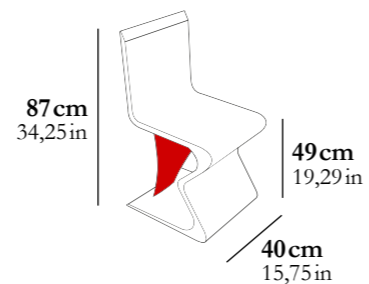
**EGG**

Poltrona comoda e stabile, utilizzabile per interni ed esterni. La forma avvolgente crea un senso di protezione. L'imbottitura interna è intercambiabile e disponibile in differenti colorazioni

Comfortable and stable armchair, usable for indoors and outdoors. The enveloping shape creates a sense of protection. The internal padding is interchangeable and available in different colours

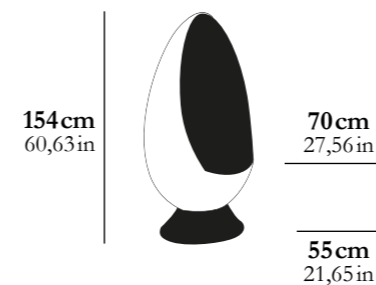
**TONGUE**

Poltroncina caratterizzata dalla forma estrema e massima comodità di seduta. Completamente personalizzabile nelle grafiche e nei colori

Armchair characterized by an extreme shape and maximum seating comfort. Fully customizable in graphics and colors

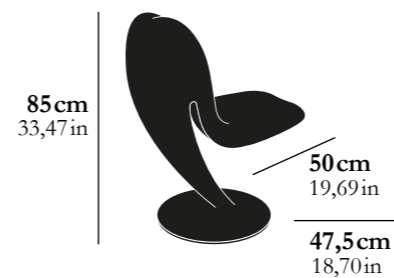

**NEST**

Seduta dal design semplice, utilizzabile in interni ed esterni, anche in abbinamento alla poltrona EGG da cui deriva. Può essere accessoriata con una imbottitura dedicata

Seat with a simple design, usable indoors and outdoors, also in combination with the EGG armchair from which it derives. It can be accessorized with a dedicated padding

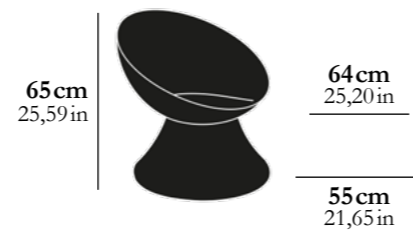

Rivestimenti

Velluto antimacchia
Stain-resistant velvet

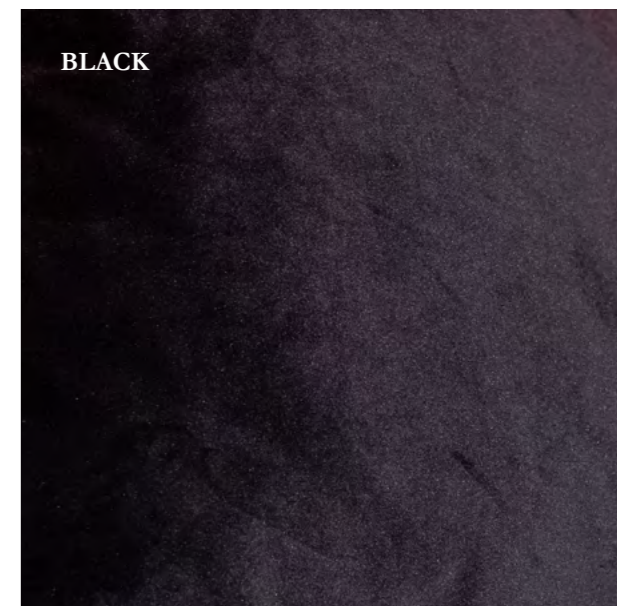

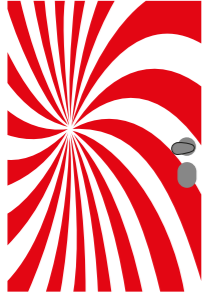
**PANNELLI**

Pannelli decorativi per porte e portoncini utilizzabili sia in interno che in esterno personalizzabili nelle dimensioni e nelle grafiche

PANELS

Decorative panels for doors and entrance doors that can be used both indoors and outdoors, customizable in size and graphics







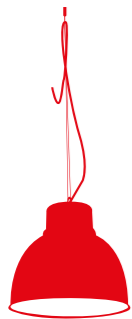

LAMPADE
Corpi illuminanti realizzati
completamente in fiberglass
e dotati di lampadine a led

LAMPS
*Lighting bodies made entirely of
fiberglass and equipped with led bulbs*



**FACTORY**

Lampada a sospensione in stile industrial.
Personalizzabile nelle colorazioni

*Industrial style pendant lamp.
Customizable in colors*

45 cm
17,72 in



47,5 cm
18,70 in

FILO

Lampada da appoggio.
L'accensione crea decorative trame di
luce e ombra

*Table lamp.
Switching it on creates decorative patterns of
light and shadow*

40 cm
15,75 in

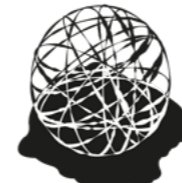

50 cm
19,69 in

**MOON**

Globo luminoso caratterizzato dalla
trasparenza che rivela la trama naturale
del fiberglass

*Luminous globe characterized by transparency
that reveals the natural texture of the fiberglass*

40 cm
15,75 in

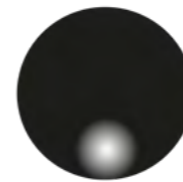

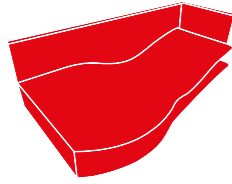

WAVE

Lavandino contenitore con finiture in gelcoat nero e Swarovski con dettagli in fibra di carbonio

Container sink with black gelcoat finish and Swarovski with carbon fibre details

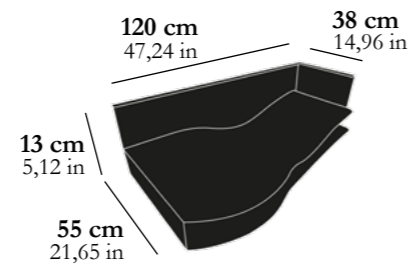



WASH HOUSE

Lavandino a lavatoio

Wash basin

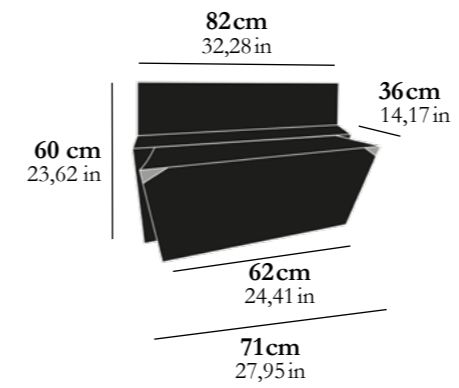

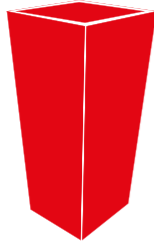
**PLINT**

Vaso da esterno con finitura in gelcoat nero o bianco e cornice in mosaico di specchio

Outdoor pot with black or white gelcoat finish and mirror mosaic frame

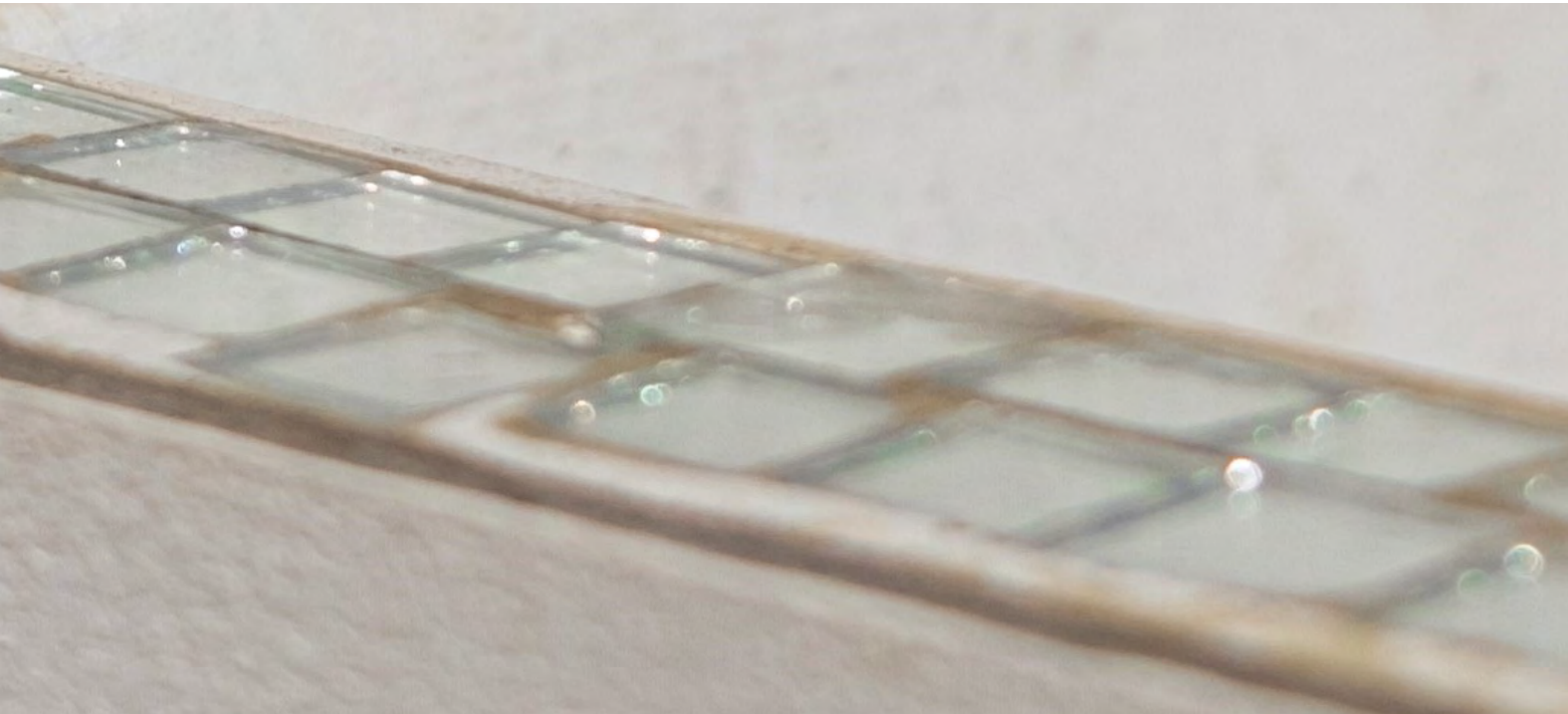
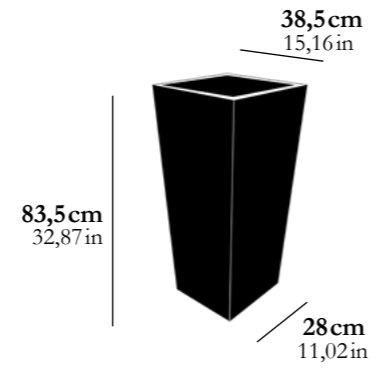

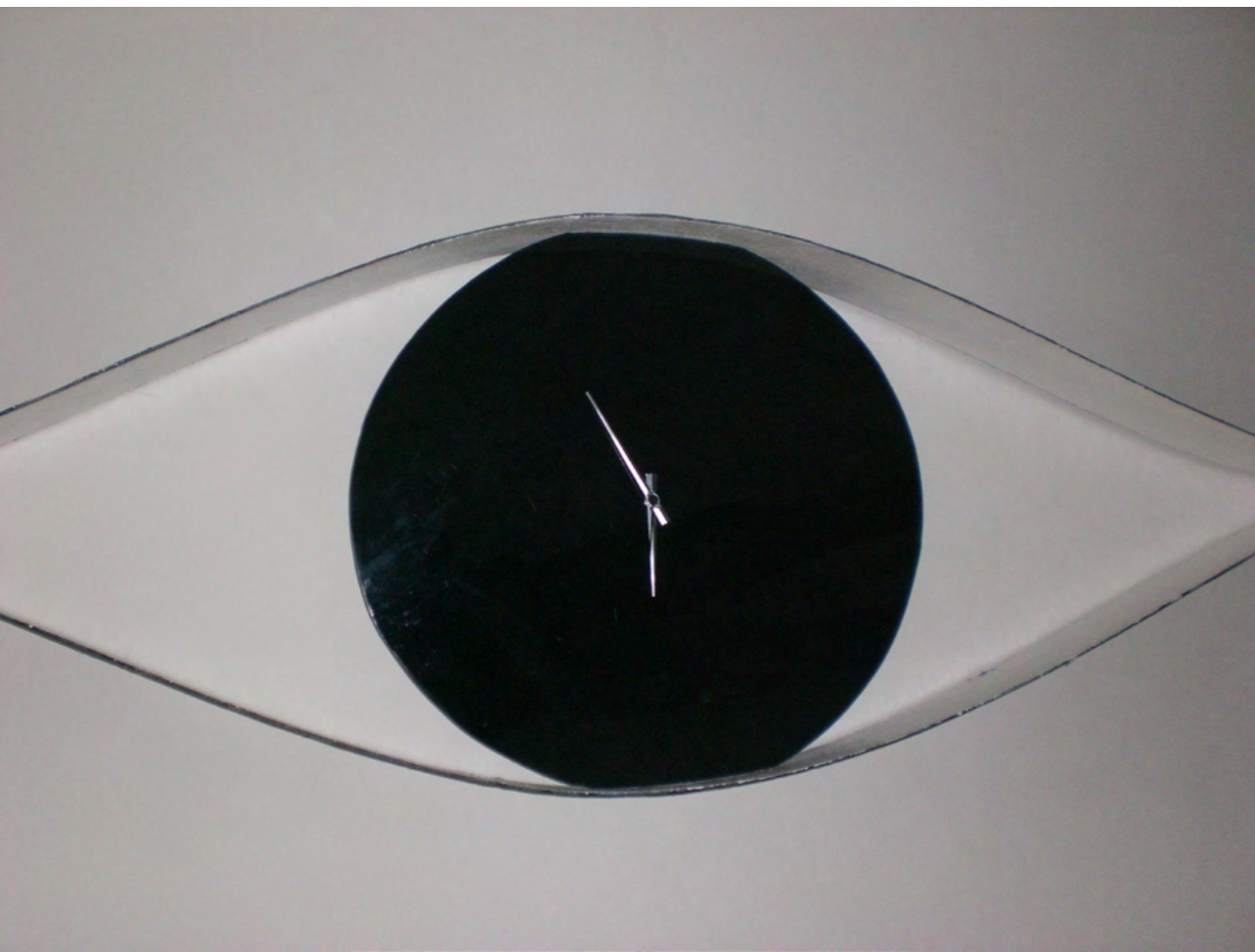

EYE

Orologio da parete

Wall clock

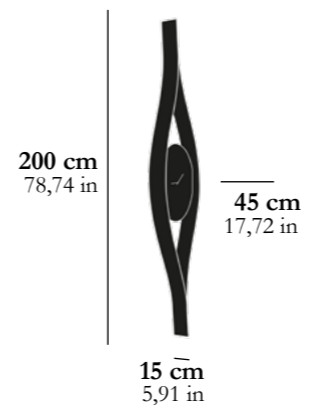



PORTA ANELLI

Piccoli accessori d'appoggio
dalle variegate finiture

*Small supporting accessories
with varied finishes*

9 cm
3,54 in



4 cm
1,57 in





CAP

Riproduzione del cappello d'artista personalizzabile a richiesta

Reproduction of artist's hat customizable on request

20 cm
7,87 in



30 cm
11,81 in





QUADRI

Soggetti personalizzabili, dimensioni varie, possibile retroilluminazione o aggiunta di Swarovski

FRAMEWORKS

Customizable subjects, various sizes, possible backlighting or addition of Swarovski











... UNA BELLA PAROLA
 PER ESPRIMERE L'EMOZIONE CHE SI
 STA PROVANDO... CORTA, SEMPLICE, DI
 GRANDE VALORE...
 DA USARE IN POCHE OCCASIONI...
 VIENE DAL CUORE
 CON SEMPLICITÀ
 E CALORE...



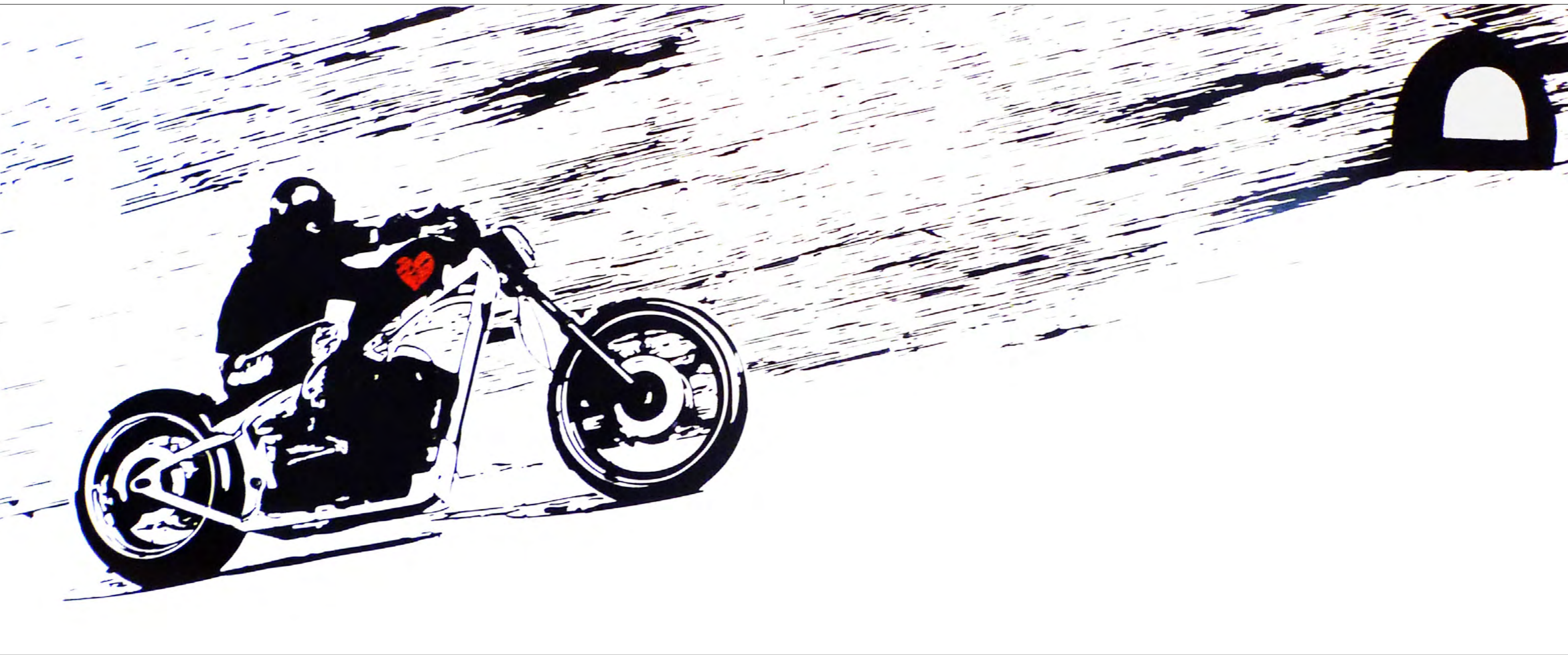

**LOCALI**

Sono realizzabili allestimenti specifici per locali pubblici e spazi privati con soggetti, dimensioni e colori a richiesta

SPACES

Site-specific project can be created for public and private spaces with subjects, dimensions and colors on request





La Barraca

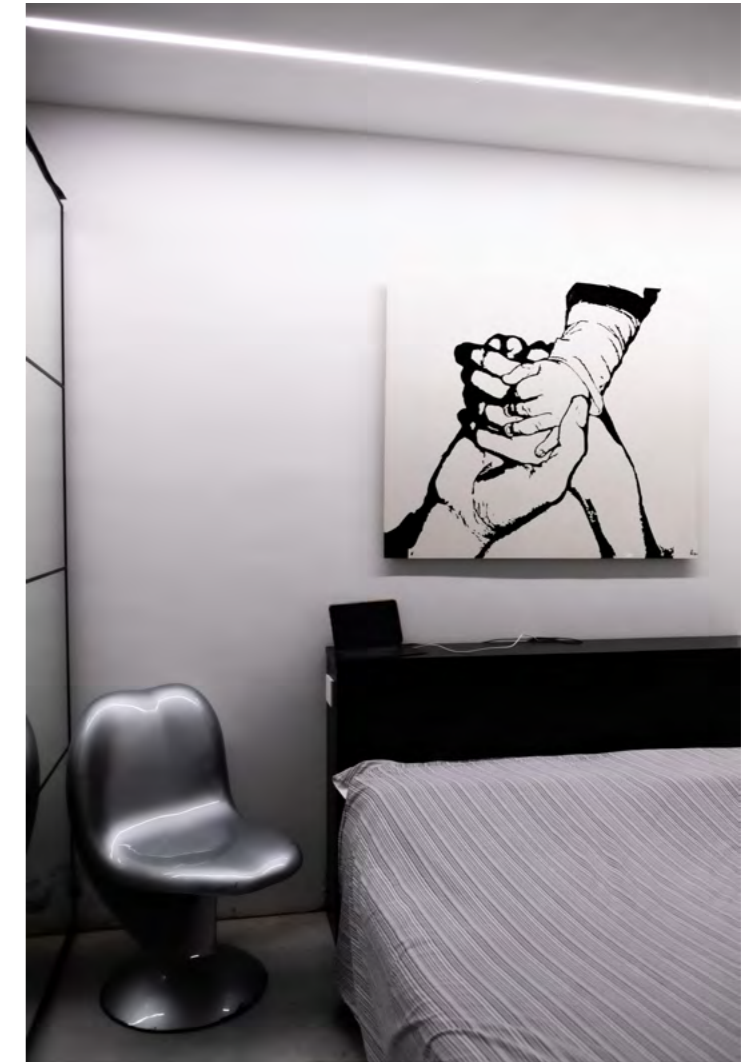

Abitazione privata















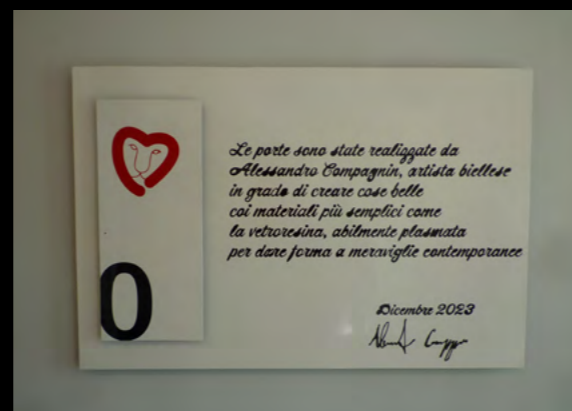





only CHOPPER

[click to see the video](#)





**PERSONALIZZABILI SU
RICHIESTA**

Sono realizzabili progetti dedicati
a temi specifici anche con inserti
di Swarovski

PROJECTS ON DEMAND

*Projects dedicated to specific themes
are possible also with Swarovski inserts*

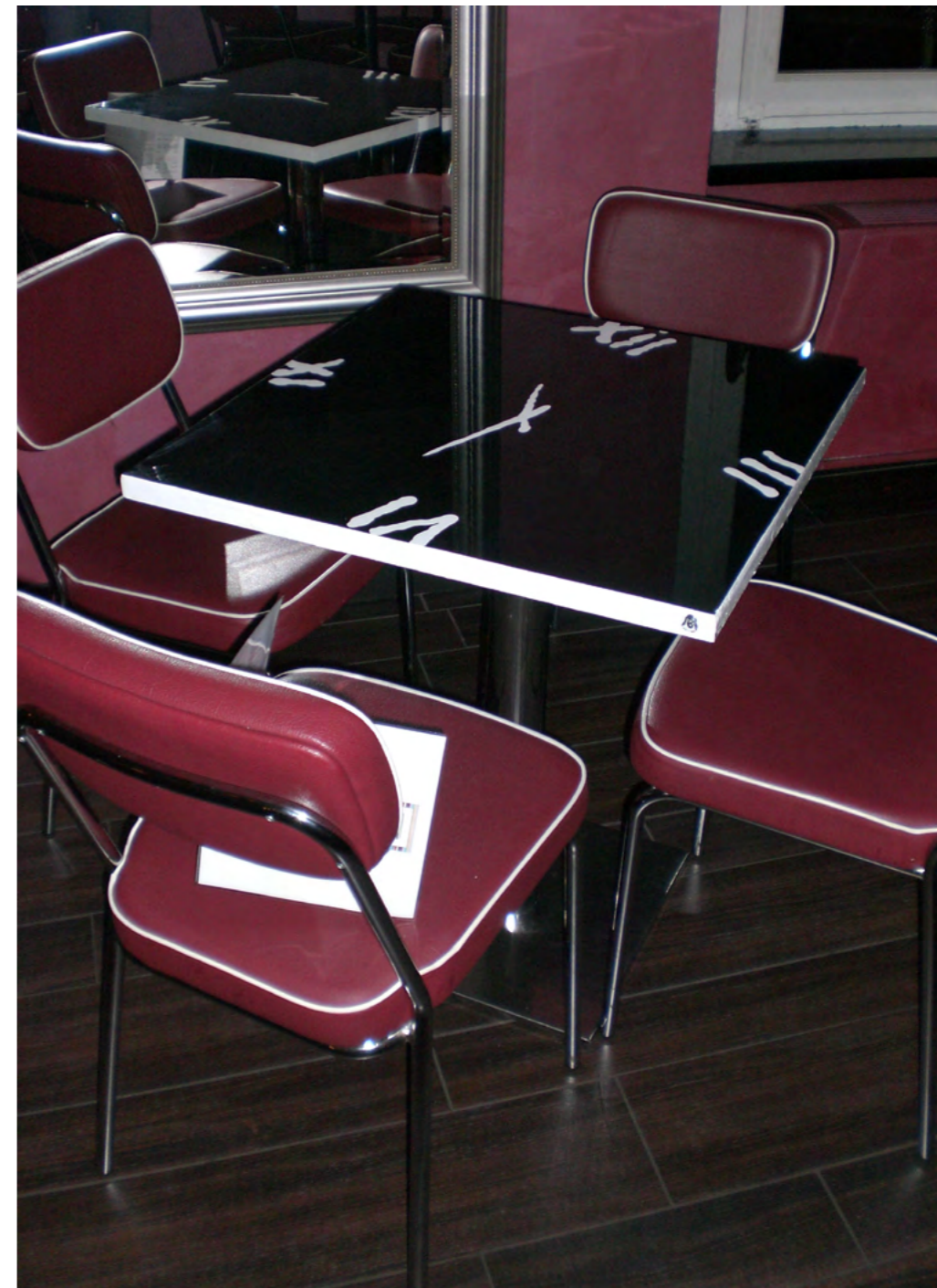



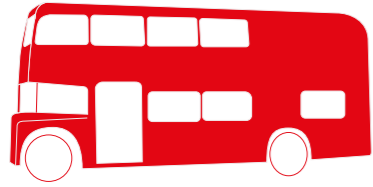

PROGETTI SU RICHIESTA
Sono realizzabili progetti dedicati
a temi specifici

PROJECTS ON DEMAND
*Projects dedicated to specific themes
are possible*





— —

**CONTATTI**

+39 338 2000499

alexcompa@libero.it

Alessandro Compagnin

[Alessandrocompagnin77](https://www.instagram.com/Alessandrocompagnin77)

www.alessandrocompagnin.it



TERMINI

Alessandro Compagnin si riserva il diritto di modificare, senza preavviso, materiali, rivestimenti, finiture e disegni dei prodotti presentati in questo catalogo. I colori e le finiture visualizzate sono puramente indicativi e possono differire dagli originali. Le immagini riprodotte nel presente catalogo sono di proprietà esclusiva di Alessandro Compagnin. È vietata qualunque riproduzione o utilizzo delle immagini senza preventiva autorizzazione scritta di Alessandro Compagnin.

TERMS

Alessandro Compagnin reserves the right to change, without any notice, materials, covers, finishes and drawings of the products of this catalogue.

Colors and finishes shown are approximate and may differ from actual ones. All images in this catalogue are property of Alessandro Compagnin.

Every reproduction or use of the images without prior written authorization from Alessandro Compagnin is therefore strictly forbidden.

© Alessandro Compagnin



Per ulteriori
informazioni vi
invitiamo a visitare il
nostro sito web.

*For further information
please visit our website.*



www.alessandrocompagnin.it

Credits

Romeo **Bazzan** Art director
Gian Luca **Bazzan** Art supervisor
Lidia Elisa **Covello** Photos
Alessandro **Bertolin** Photos



Alessandro Compagnin®